

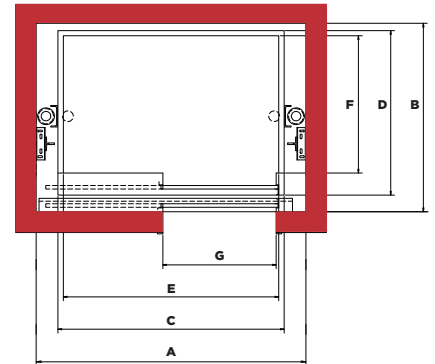

FREEDOM® HYDRAULIC DUAL HOLELESS 1 - STAGE

FRONT

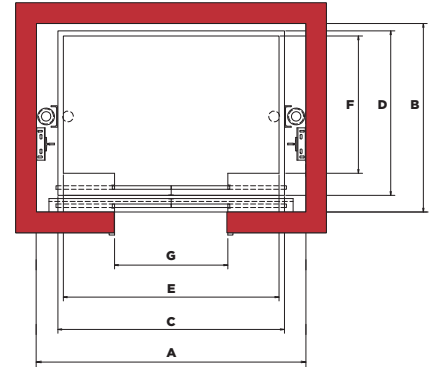
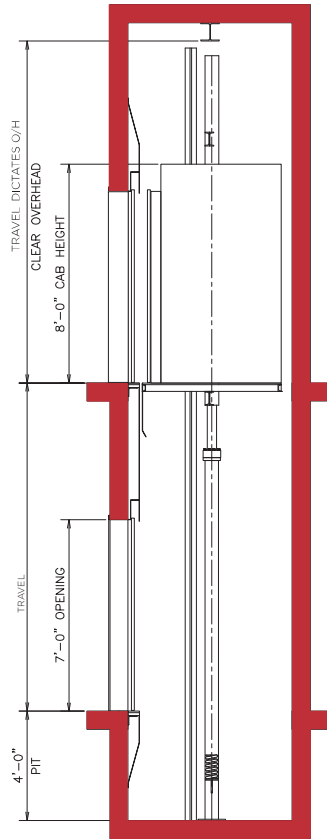

PASSENGER DUAL HOLELESS SINGLE STAGE					FRONT OPEN ONLY	
Type	Capacity (lbs)	Hoistway	Platform	Inside Cab	Door Type	Door Width G
		Width x Depth A x B	Width x Depth C x D	Width x Depth E x F		
Passenger	2000	7'-4" x 5'-10"	6'-0" x 5'-1"	5'-8" x 4'-3"	Single Speed	3'-0"
	2500	8'-4" x 5'-10"	7'-0" x 5'-1"	6'-8" x 4'-3"	Single Speed	3'-6"
	2500	8'-4" x 5'-10"	7'-0" x 5'-1"	6'-8" x 4'-3"	Center Opening	3'-6"
	3000	8'-4" x 6'-3"	7'-0" x 5'-6"	6'-8" x 4'-8"	Single Speed	3'-6"
	3000	8'-4" x 6'-3"	7'-0" x 5'-6"	6'-8" x 4'-8"	Center Opening	3'-6"
	3500	8'-4" x 6'-11"	7'-0" x 6'-2"	6'-8" x 5'-4"	Single Speed	3'-6"
	3500	8'-4" x 6'-11"	7'-0" x 6'-2"	6'-8" x 5'-4"	Center Opening*	3'-6"
	4000	9'-4" x 6'-11"	8'-0" x 6'-2"	7'-8" x 5'-4"	Single Speed	4'-0"
Hospital	4000	7'-4" x 9'-6"	6'-0" x 8'-8"	5'-8" x 7'-8 1/2"	Two Speed	4'-0"
	4500	7'-4" x 9'-11"	6'-0" x 9'-1"	5'-8" x 7'-8 1/2"	Two Speed	4'-0"
	5000	8'-2" x 10'-5"	6'-0" x 9'-7"	5'-8" x 7'-8 1/2"	Two Speed	4'-6"

NOTES:

- 2000-lb. car complies with NEII recommendations for car to accommodate wheelchair.
- 3500-lb. and larger cars comply with NEII recommendations for car to accommodate ambulance size stretcher when equipped with single slide doors.
- Consult factory for any nonstandard sizes not shown on the charts above.

*Center parting doors do not allow stretchers.



FREEDOM® HYDRAULIC DUAL HOLELESS 1 - STAGE FRONT & REAR

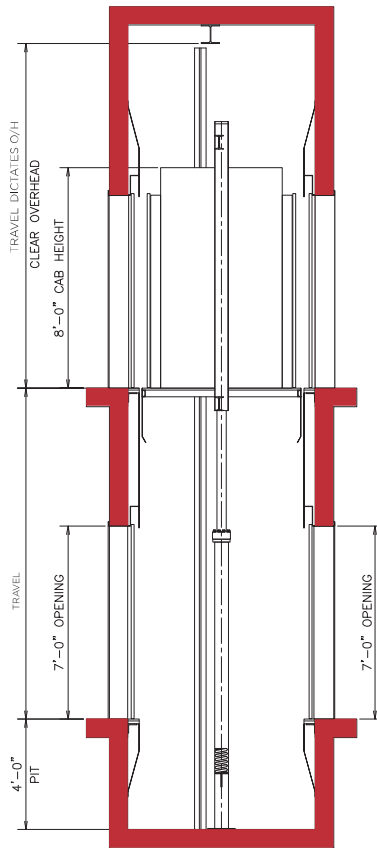
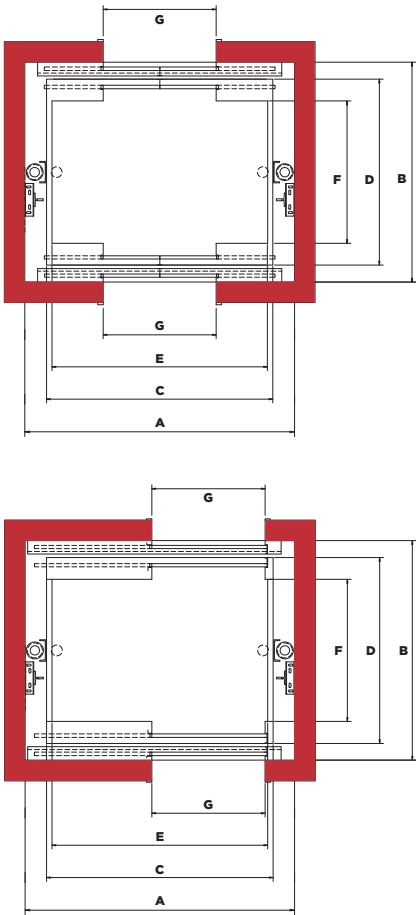

Description: The design utilizes two hydraulic single stage jacks, located on each side of the platform and installed directly on the pit floor. Opening configuration available in walk-thru and/or staggered. Staggered doors are required to accommodate the ambulance size stretcher.

Advantages:

- Jack hole is not required, eliminating the cost of drilling and the risk of ground contamination from oil leak
- Offered in a wide range of capacities.
- Accommodates front and rear opening configurations

PASSENGER DUAL HOLELESS SINGLE STAGE					FRONT & REAR OPEN	
Type	Capacity (lbs)	Hoistway	Platform	Inside Cab	Door Type	Door Width G
		Width x Depth A x B	Width x Depth C x D	Width x Depth E x F		
Passenger	2000	7'-4" x 6'-9 1/2"	6'-0" x 5'-9"	5'-8" x 4'-4 3/4"	Single Speed	3'-0"
	2500	8'-4" x 6'-9 1/2"	7'-0" x 5'-9"	6'-8" x 4'-4 3/4"	Single Speed	3'-6"
	2500	8'-4" x 6'-9 1/2"	7'-0" x 5'-9"	6'-8" x 4'-4 3/4"	Center Opening	3'-6"
	3000	8'-4" x 7'-1 1/2"	7'-0" x 6'-1"	6'-8" x 4'-8 3/4"	Single Speed	3'-6"
	3000	8'-4" x 7'-1 1/2"	7'-0" x 6'-1"	6'-8" x 4'-8 3/4"	Center Opening	3'-6"
	3500	8'-4" x 7'-9 1/2"	7'-0" x 6'-9"	6'-8" x 5'-4 3/4"	Single Speed	3'-6"
	3500	8'-4" x 7'-9 1/2"	7'-0" x 6'-9"	6'-8" x 5'-4 3/4"	Center Opening*	3'-6"
	4000	9'-4" x 7'-9 1/2"	8'-0" x 6'-9"	7'-8" x 5'-4 3/4"	Single Speed	4'-0"
Hospital	4000	7'-4" x 10'-7 1/2"	6'-0" x 9'-4"	5'-8" x 7'-8 3/4"	Two Speed	4'-0"
	4500	7'-4" x 11'-1 1/2"	6'-0" x 9'-9"	5'-8" x 8'-1 3/4"	Two Speed	4'-0"
	5000	8'-2" x 11'-6 1/2"	6'-0" x 10'-3"	5'-8" x 8'-7 3/4"	Two Speed	4'-6"

IMPORTANT:

This information is intended for preliminary planning. We have attempted to include the basic data required for your planning efforts. For details about specific or custom installations, please contact your local Canton Elevator representative or contact us directly.

